

Operating instructions

for freezer with electronic controls

GB

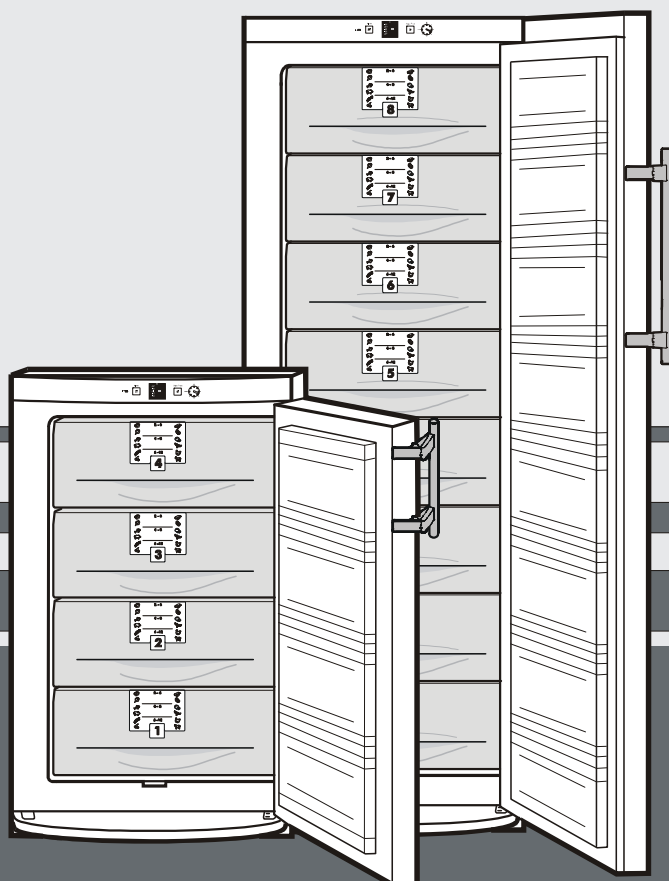

7082 200-00

G/GSS/Ges..3 0304

LIEBHERR

The appliance at a glance

Control setting for temperature ①

fig. A1

Setting 1 = warm

Setting "max." = kalt

- Recommended setting: -18°C

SuperFrost

For fast freezing of fresh food:

- Press the SuperFrost button ② briefly so that it lights up.
- The freezer will take approx. 6 - 24 hours to reach its lowest temperature.
- Place the fresh food in the top drawers.
- The SuperFrost function **switches off automatically** after about 65 hours.

Operating and control elements

fig. A1

- ① On/off and temperature control
- ② SuperFrost button, lit = function activated
- ③ Freezer temperature setting display
- ④ Audible warning on/off button with visual warning light: temperature too high

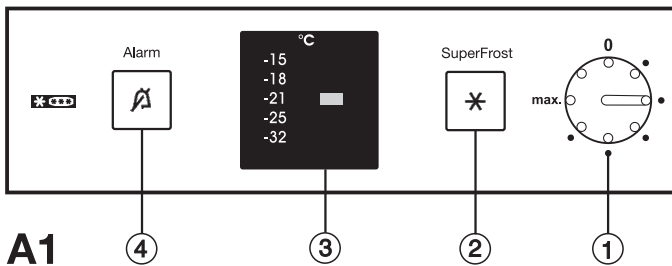

A1

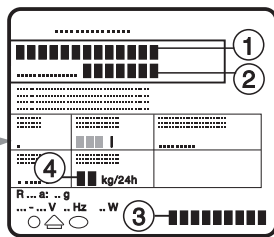

A2

Type/Data plate, fig. A2

- ① Type designation
- ② Service number
- ③ Appliance number
- ④ Freezing capacity in 24 hours

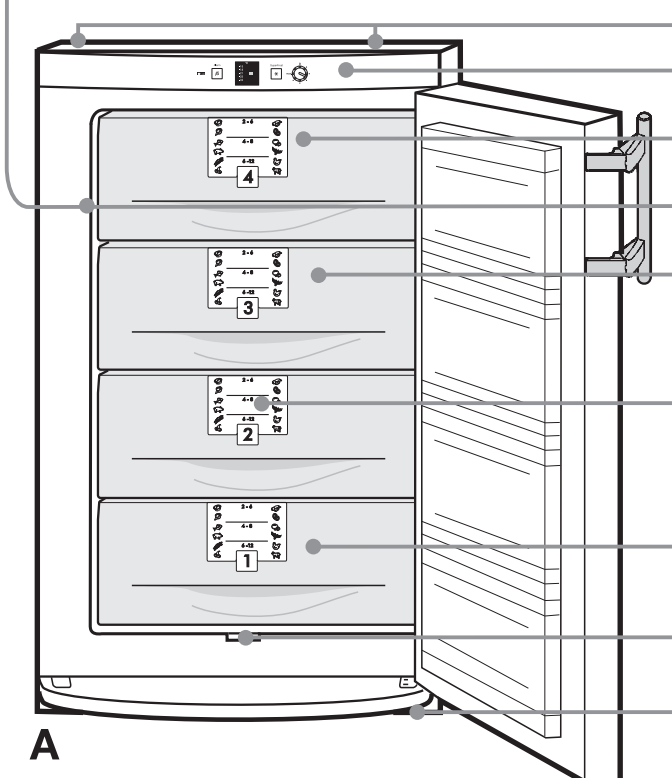

A

Rear transport grips

Operating and control elements

Freezer tray*, cold-storage accumulator*

Type/Data plate

VarioSpace*

Drawers with information system*

Ice-cube tray*

Defrost drain

Adjustable-height feet, front transport grips, transport castors at back

Congratulations on your purchase. In choosing this appliance you have opted for all the benefits of state-of-the-art refrigeration technology which will guarantee you a top quality product with a lengthy, reliable operating life.

The equipment in your appliance will provide you with optimum operating comfort every day.

This appliance is manufactured in environmentally-friendly processes using recyclable materials. This enables you and us to both play an active role in preserving our environment.

In order to get to know all the benefits of your new appliance, please read the information in the operating instructions through carefully.

We wish you much pleasure with your new appliance.

Keep the operating instructions in a safe place and pass them on to the next owner of your appliance where applicable.

The operating instructions apply to several models. Differences may therefore occur.

Contents

	Page
Operating instructions	
The appliance at a glance	10
Contents, Safety regulations	11
Energy savings	11
1 Safety instructions and warnings	12
Disposal notes	12
Setting up	12
2 Operation and control elements	13
Connecting to the mains	13
Switching the appliance on and off	13
Setting the temperature	13
Temperature setting display	13
Audible warning signal, red visual warning light	13
3 SuperFrost	14
Notes on freezing and storage	14
VarioSpace*	14
4 Equipment	15
Information system	15
Freezer tray	15
Cold-storage accumulators	15
Making ice-cubes	15
5 Defrosting	15
Cleaning	15
6 Troubleshooting	16
Customer service and type plate	16
Instructions for installation and modification	
Dimensions	16
Changing over door hinges	16
Insertion into row of kitchen units	17
Notes on assembling decor panels	17

Safety regulations

- The appliance is designed to freeze and store food and to make ice. It is designed for household use. If used for commercial purposes, the relevant legal regulations applicable to the trade concerned must be observed.
- This appliance is set to operate within specific ambient temperature limits according to its own specified climate rating. These temperature limits should not be exceeded. The correct climate rating for your appliance is indicated on the type plate. This is explained as follows:

Climate rating	Set for ambient temperatures
SN, N	up to +32°C
ST	up to +38°C
T	up to +43°C

- The appliance will function properly in ambient temperatures of down to +5°C.
- The refrigerant circuit has been checked for leaks.
- This appliance corresponds to the relevant safety provisions and EC directives 73/23/EEC and 89/336/EEC.

Notes on energy saving

- Ensure that the ventilation spaces are free.
- Avoid keeping the door open for too long.
- Store food logically. Do not exceed the storage period specified.
- Keep all food properly packed and covered so as to avoid its frosting up on the outside.
- Always allow hot food to cool to room temperature before placing in the appliance.
- Defrost frozen food in the refrigerator.
- If an ice layer forms in the freezer defrost it. This will improve the cold transfer and reduce energy consumption.
- Keep the appliance door shut in the event of a breakdown. This will delay the cold loss and will help to maintain the quality of the frozen food for longer.

1 Safety instructions and warnings



Disposal notes

The packaging is designed to protect the appliance and individual components during transport and is made of recyclable materials.

- Corrugated board/board
- Moulded polystyrene (foamed, CFC-free polystyrene)
- Polythene bags and sheets
- Polypropylene straps
- **Keep packaging materials away from children - polythene sheets and bags can suffocate!**
- Please return the packaging material to your nearest official collection point so that the various materials can be reused or recycled as far as possible.

Your old appliance:

This contains some reusable materials and should not simply be disposed of with household or bulk refuse.

- Disable discarded appliances immediately by removing the plug and cutting through the connection cable.
- Remove the spring-action or bolt catch from the appliance or render it unusable so that children cannot become trapped inside and suffocate.**
- Ensure that the refrigerant circuit is not damaged before the appliance that is no longer needed is taken away for disposal. In this way the refrigerant or oil will not escape into the environment.
- Exact details of the refrigerant used can be found on the type plate. The heat insulator is PU with Pentane.
- Information on collection dates or collection points can be obtained from the waste disposal authorities or local council.

Technical safety



- To prevent injury or damage to the unit, the appliance should only be transported wrapped and set up by two people.
- The refrigerant R 600a is environmentally friendly but flammable.
- Do not damage the refrigerant circuit pipes. Splashes of refrigerant can harm your eyes or ignite.
- If refrigerant escapes, remove all naked flames or sources of ignition in the vicinity of the leak, disconnect the appliance from the mains and ventilate the area well.
- In the event that the appliance is damaged, contact the supplier immediately before connecting to the mains.
- To guarantee safe operation, ensure that the appliance is set up and connected as described in these operating instructions.
- Disconnect the appliance from the mains if any fault occurs. Pull out the plug (not by pulling on the mains cable) or switch off or remove the fuse.
- **Any repairs and work on the appliance should only be carried out by the customer service department, as unauthorised work could prove highly dangerous for the user.** The same applies to changing the mains power cable.

Safety during use



- Do not store explosives or sprays using combustible propellants such as butane, propane, pentane, etc. in the appliance. Electrical components might cause leaking gas to ignite. You can identify such sprays by the printed contents or a flame symbol.
- Only store high-percentage alcohol in tightly sealed, upright containers.
- Do not allow naked flames or ignition sources to enter the appliance.
- Do not use electrical appliances inside the appliance (e.g. steam cleaners, heaters, ice makers, etc.).
- Do not stand on the plinth, drawers or doors or use them to support anything else.
- Do not let children play with the appliance, e.g. do not allow them to sit in the drawers or swing on the door.
- The appliance is not intended for use by young children or infirm persons without supervision.
- Do not eat ice-cream, particularly ice lollies or ice-cubes, immediately after taking them from the freezer compartment as there is a risk of "burning" because of the very cold temperatures.
- Do not consume food which has been stored for too long, as it could cause food poisoning.

Setting up



- When setting up/fitting ensure that the refrigerant circuit pipes are not damaged.
- Once in position, use the 10 spanner provided to adjust the feet so that the appliance is level and does not wobble.
- Avoid positioning in direct sunlight or next to an oven, radiator or similar, in damp locations or near spraying water.
- The basement is an ideal site for installation.
- Standard EN 378 specifies that the room in which you install your appliance must have a volume of 1 m³ per 8 g of R 600a refrigerant used in the appliance, so as to avoid the formation of inflammable gas/air mixtures in the room where the appliance is located in the event of a leak in the refrigerant circuit. The quantity of refrigerant used in your appliance is indicated on the type plate on the inside of the appliance.
- **The ventilation grilles should not be obstructed. Always ensure that there is good ventilation and that the outward flowing air is able to escape.** Please note the appendix concerning installation instructions.
- Do not place heat-emitting appliances, e.g. microwave oven, toaster, etc., on top of the refrigerator or freezer.
- When you open the door for the first time, the handle* switches from the transport position to the operating position; you will hear a soft click.
- Remove all transportation safety components.



2 Operation and control elements

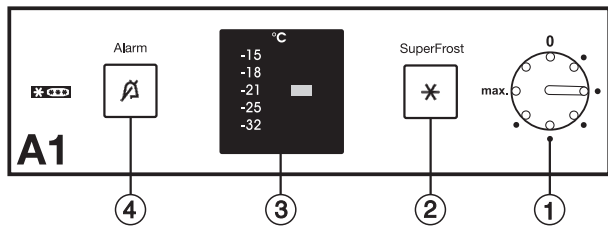

You are advised to clean the appliance before switching it on for the first time (see "Cleaning"). Switch on the appliance approx. 4 hours before loading it with frozen food for the first time.

Connecting to the mains

Power supply (AC) and voltage

at the operating point must comply with the details on the type plate, which is located inside the appliance on the left, fig. A.



- **Connect the appliance with a properly earthed fused plug and socket only.**
- The socket must be fused with a 10 A fuse or higher, it must be away from the rear of the appliance and must be easily accessible.
- *Do not*
 - connect to stand-alone inverters,
 - operate with so-called energy-saving plugs - this can damage the electronic system,
 - connect to the supply with other equipment using an extension cable - risk of overheating.
- When removing the mains cable from the back of the appliance, remove the **cable holder** as well so as to avoid vibration noise.

The wires in the mains lead are coloured in accordance with the following code: green/yellow = earth, blue = neutral, brown = live.

Warning! This appliance must be earthed.

Non-rewireable plugs BS 1363

If this machine or appliance is fitted with a non-rewireable plug, the following information applies: If the socket outlets are not suitable for the plug supplied with this product, it must be cut off and an appropriate plug fitted. The plug cut from the flexible cord should be disposed of and on no account be inserted into a 13 A socket elsewhere in the house (electric shock hazard).

The fuse cover **must** be re-fitted when changing the fuse, and if the fuse cover is lost the plug **must not** be used until a suitable replacement is obtained. The colour of the correct replacement cover is that of the coloured insert in the base of the plug, or the colour that is embossed in words on the base of the plug (as applicable to the design of the plug fitted). The correct rating of the replacement fuses that are ASTA approved to BS 1362 should be fitted. Replacement fuse covers may be purchased from your local electrical suppliers, electricity showroom or approved service agent.

Switching the appliance on and off

fig. A1

- **To switch on:** Turn the temperature control ① with a coin so that the slot is pointing to setting 2.
- The red visual warning light will be on until the freezer has reached a sufficiently low temperature, then it goes out. See "Audible warning signal, red visual warning light" for more information.

- A green light on the temperature display will light up and indicate that the appliance is in normal mode.

- **To switch off:** Set the temperature control to "0".
- The temperature display and all buttons will go out.

Setting the temperature

fig. A1

- Turn the temperature control with a coin until the desired temperature is indicated in the display. The slot positions mean:
 - Setting 1** = **highest temperature**, lowest cooling setting
 - Setting "max."** = **lowest temperature**, highest cooling setting
- Recommended temperature setting: -18°C.

Temperature setting display

fig. A1/③

- When the temperature display is illuminated, this indicates that the appliance is running.
- The five blocks in the display each relate to a different temperature range. They indicate the freezer temperature setting you have selected.

Audible warning signal, red visual warning light

fig. A1

The audible warning signal and the red visual warning light are designed to help you to protect your frozen food and to save energy.

- **The audible warning device is switched off** by pressing the audible warning on/off button ④.
 - It switches off automatically as soon as the temperature is low enough.
 - It always sounds if the freezer temperature is not low enough (dependent on the temperature setting).
 - The **red** visual warning light will *flash* simultaneously. This can be caused by:
 - warm, fresh food being placed in the freezer,
 - too much warm air from the outside entering when re-arranging or removing frozen food. These temperature fluctuations will not affect the quality of the frozen food.
 - When the audible warning on/off button is pressed, the **visual warning light** will stop flashing and will light up continuously. It will only go out once the alarm status stops and the temperature inside the freezer is low enough. The audible warning signal will then *switch back to standby* automatically.
- If the SuperFrost button light *flashes at the same time* as one of the lights on the temperature display, this means that your appliance has a fault. Contact your customer service department and tell them that this visual warning is active, so that they can arrange for your appliance to be serviced accurately and quickly.

3 SuperFrost, notes on freezing and storage

SuperFrost

Fig. A1/②. *Fresh* food should be frozen to the core as rapidly as possible. Frozen food can also be given a cold boost. This is provided by the SuperFrost facility and ensures that the nutritional value, appearance and flavour of the food remain intact.

- The maximum amount of food which can be frozen in 24 hours is shown on the type plate ("Freezing capacity ... kg/24h"). This amount varies according to the model and climate rating.

Freezing with SuperFrost

- Press the SuperFrost button ② briefly until it lights up; the lowest set temperature on the temperature display will also light up.  The freezer temperature will decrease and the appliance will switch to the lowest temperature.
- For small amounts of frozen food, it is normally sufficient to switch on SuperFrost 6 hours beforehand. For the *maximum* amount (see freezing capacity on the type plate) you will need to switch it on 24 hours beforehand.
- Then place the fresh food inside the freezer, preferably in the top drawers.
If freezing the *maximum* quantity of food, do *not* use the drawers; instead, place the wrapped food directly on the cooling plates. Once the food is frozen you can load it into the drawers.
 - The SuperFrost function switches **off automatically** after about 65 hours. The freezing process is now finished; **the SuperFrost button has gone out**, the set temperature is displayed again and the appliance has switched back to energy-saving normal mode.

You should *not* switch on the SuperFrost function:

- when placing frozen food in the freezer;
- when freezing up to approx. 2 kg fresh food daily.

Notes on freezing and storage

- **Items suitable for freezing:** meat, game, poultry, fresh fish, vegetables, fruit, dairy products, bread, baked goods, pre-cooked meals.
Not suitable: lettuce, radishes, grapes, whole apples and pears, fatty meat.
- **Pack frozen food** in standard freezer bags or re-usable plastic, metal or aluminium containers.
- Do not allow fresh food which is to be frozen to come into contact with food already frozen. Always keep packs dry in order to avoid them sticking together.
- Always write the date and contents on the pack and do not exceed the stated storage time for the food. This prevents any risk of quality impairment.
- Pack food which you are freezing yourself in quantities appropriate to your household. To ensure that the food freezes right through quickly, the following quantities should not be exceeded per package:
 - fruit, vegetables: up to 1 kg;
 - meat: up to 2.5 kg.
- Blanch **vegetables** after washing and cutting them. (Add to boiling water for 2-3 minutes, remove and quickly cool down in cold water. If you blanch with a steamer or microwave oven, please observe the relevant operating instructions.)
- Do not salt or season fresh food or blanched vegetables before freezing. Only lightly salt and season other food. Some spices can alter their flavour intensity.

- Do not freeze bottles and cans which contain carbonated drinks as they might burst. Drinks can be cooled down quickly, but take the bottles out of the freezer compartment after an hour at the most.
- **Storage:** Each drawer and cooling plate can take up to 25 kg frozen food.
- If you want to use the maximum net capacity, you can remove the drawers and store items directly on the cooling plates. This will enable you to make use of the entire volume of the compartment.
- **Removing drawers:** Pull forward until the drawer stops and lift out.
- Always store identical food items together to avoid the door being open for unnecessarily long periods and to save energy.
- Do not exceed storage times given.
- **Thawing:** Only take out as much food as is immediately required for thawing. Cook food which has been thawed as quickly as possible. Frozen food can be thawed in the following ways:
 - in a conventional or fan oven
 - in a microwave oven
 - at room temperature
 - in the refrigerator: the cold given off by the frozen food is used for cooling the other food.
 - Flat portions of meat or fish can be cooked when partially thawed.
 - Vegetables can be cooked from frozen (in half the normal time).



VarioSpace*

(in appliances 660 mm wide)













- You can create a double-height space for **big items of frozen food** by removing the 4th drawer and a shelf. This enables you to freeze such things as poultry or big pieces of meat without having to cut them up first, so they can be served "whole" afterwards, and to store other large items such as big gateaux or packs of ice.
- Fig. K1/2: Remove the 3rd and 4th drawers, press down the catch at the back underneath the shelf and slide the shelf out towards you. Replace the 3rd drawer and use to store your bulky items.
 - To insert: slide shelf in and make sure it clicks into place.



4 Equipment

Information system*

Use frozen food within the recommended period. The numbers between the symbols indicate the storage period in months for different kinds of frozen foods. Storage times given are guide times for food frozen at home. Whether or not the lower or upper value is applicable depends on the food quality and how it was processed prior to freezing. The lower values always apply to food with a high fat content.

pre-cooked meals		2 - 6		sausages
ice-cream		4 - 8		bread
fish				mushrooms
pork		6 - 12		game
vegetables				poultry
fruit		2		beef/veal

Freezer tray*

This is used for gently freezing berries, herbs, vegetables and other small items and prevents them from sticking together. Items being frozen will largely retain their shape, and it will be easier to remove exactly the right quantity later on.

- Spread the items out loosely on the tray, fig. H.
- Suspend the freezer tray in one of the top drawers. Freeze for 10 to 12 hours, then transfer to a freezer bag or container and put in a drawer.
- To defrost, spread the frozen items out loosely.

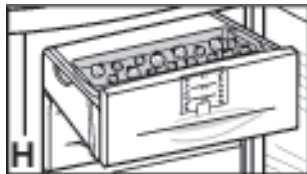

Cold-storage accumulators*

These prevent the temperature in the freezer from rising too quickly in the event of a power failure, thus preserving the quality of the food.

- To save space, you can freeze and store the cold-storage accumulators in the freezer tray, fig. I.
- To ensure maximum storage time in the event of a power failure, place the *frozen* cold-storage accumulators in the top freezer drawer on top of the food.

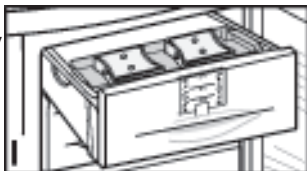

Making ice-cubes

- Press the locking bolt downwards.
- Fill the ice-cube tray with water. Surplus water will flow through the drain hole.
- Push the locking bolt upwards.
- Place the ice-cube tray in the appliance and leave it to freeze.
- The ice-cubes can be removed from the tray by twisting or by holding upside down for a short time under running water.

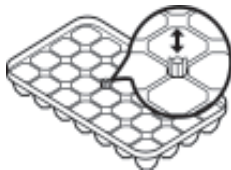

5 Defrosting, cleaning

Defrosting

After the appliance has been in operation for some time, a layer of ice will form on the aluminium panels and the fronts of the drawers if the door is opened and fresh food placed inside the freezer regularly. This is completely normal.

However, a thick layer of ice will increase the appliance's energy consumption. You should therefore defrost the appliance regularly:

- Switch on SuperFrost the day before defrosting to give the food a cold boost.
 - To defrost, switch off the appliance:
 - Disconnect the appliance from the mains or set the temperature control to "0".
 - If possible, put the frozen goods in the freezer drawer with the cold-storage accumulators on top, wrap in newspaper or a blanket and store in a cool place.
 - Pull out the defrost drain pipe ① and place the freezer tray* or a suitable container underneath.
 - To speed up the defrosting process put a saucepan of hot but not boiling water on one of the shelves.
- Do not use electric heaters or steam cleaners, defrosting sprays or naked flames for defrosting nor any metal objects for removing the ice. Risk of injury and damage!**
- Leave the door of the appliance open while defrosting. After defrosting, mop up the remaining water. Then clean the appliance.



Cleaning

- **Always disable the appliance for cleaning. Disconnect from the mains or unscrew or switch off the fuse.**
- Clean the outer walls, inside and equipment by hand with lukewarm water and a little detergent. Because of the risk of injury and damage to the appliance, steam cleaning equipment should not be used.
- We recommend using a soft cloth and an all-purpose cleaner with a neutral pH value. Only use food compatible cleaning and care agents on the inside of the appliance.
- Use a commercially available *stainless-steel cleaning agent for stainless-steel appliances**.
 - In order to achieve best possible protection, apply a *stainless-steel care agent* uniformly in grinding direction after cleaning. Points which are darker at the start and a more intensive coloration of the stainless-steel surface are normal.
 - Do not use abrasive sponges or scourers, do not use concentrated cleaning agents and never use cleaning agents containing sand, chloride or acid or chemical solvents, as these would damage the surfaces and could cause corrosion.
- Ensure that no cleaning water is allowed to penetrate into the electrical components or ventilation grilles. Dry the appliance.
- Do not damage or remove the type plate on the inside of the appliance as this is important for customer service.
- The dust should be removed from the **refrigeration unit** and heat exchanger - metal grid at the back of the appliance - once a year. Dust deposits increase energy consumption.
- Ensure that none of the wires or other components are dislodged, bent or damaged.
- Then connect/switch on the appliance, switch on SuperFrost and start to insert the food to be frozen as the temperature drops.



* Depending on model and options

If the appliance is to be left **out of operation for any length of time**, empty it, disconnect from the mains, clean as described above and leave the door open in order to avoid unpleasant smells.

6 Troubleshooting

Your appliance is designed and manufactured for a long life span and reliable operation.

If a malfunction nonetheless occurs during operation, check whether it is due to an operating error. Please note that even during the warranty period the resultant servicing costs in this case will have to be borne by the owner.

You may be able to rectify the following faults by checking the possible causes yourself

Malfunction - Possible cause and remedy

Appliance does not work

- Is the appliance switched on properly?
- Is the mains plug properly inserted in the socket?
- Is the socket fuse intact?

Loud running noise

- Is the appliance standing firmly on the floor, or does the compressor cause nearby items of furniture or objects to vibrate?

If necessary, move the appliance slightly, align by adjusting the adjustable feet, or move bottles and containers apart.

- *Burbling noises* are normal. These are caused by the refrigerant flowing round the refrigerant circuit. A short *clicking sound*: This will be heard whenever the refrigeration unit (the motor) switches on or off automatically.

Motor noise: This will be slightly louder for a brief period when the refrigeration unit switches on.

The audible warning signal sounds, the red audible warning on/off button is lit, the temperature is not cold enough

- Have you put too much fresh food into the freezer *without* activating SuperFrost? (See "SuperFrost")
- Does the door close properly?
- Is the appliance sufficiently well ventilated? Clear ventilation grilles if necessary.
- Is the ambient temperature too hot? (See "Safety regulations")
- Has the appliance been opened too often or left open too long?
- If applicable, wait until the appliance reaches the required temperature itself.

If the red visual warning light *flashes at the same time* as one of the lights on the temperature display, this means that your appliance has a fault.

The outside of the appliance may feel warm in places

- That is quite normal. The heat from the cooling circuit is used to avoid the formation of condensate.

Customer service and type plate

If none of the above causes apply and you cannot rectify the fault yourself, or if *several lights are flashing simultaneously*, please contact your nearest customer service department (see enclosed list for addresses). State the:

- type designation ①,
- service number ② and
- appliance number ③

as given on the type plate and specify

which lights are flashing, so as to

ensure rapid, accurate servicing. The type plate is located inside the freezer compartment on the left-hand side.

Leave the appliance shut until the customer service engineer arrives so as to prevent any further cold loss.

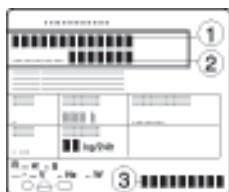

Instructions for installation and modification

Dimensions

The external dimensions of the appliance can be seen on fig. S and in the table below.

Gross capacity of appliance [l] (see type plate)	External dimensions [mm]					
	A	B	C	D	E	F
147 (16..)	1033	600	631	614	644	1179
186 (20..)	1250	600	631	614	644	1179
224 (24..)	1447	600	631	614	644	1179
263 (27..)	1644	600	631	614	644	1179
301 (31..)	1841	600	631	614	644	1179
217 (22..)	1250	660	683	662	704	1287
262 (27..)	1447	660	683	662	704	1287
307 (31..)	1644	660	683	662	704	1287
351 (36..)	1841	660	683	662	704	1287

Installation instructions

- *Do not* install models *without* side-wall heating side-by-side with another refrigerator or freezer. This is important to prevent condensation and consequential damage from it.
- Models *with* side-wall heating (for example C 2723) are designed for side-by-side installation; they are designed for combination with a refrigerator. Contact your dealer for more information.
- Attachment instructions are supplied in the accessories bag of the appliance with side-wall heating.

Changing over door hinges

Fig. T. The door hinges can be changed from one side to the other if required.

Only change over door hinges when mains plug is disconnected!

- With the door open, lever out plinth panel ① on the hinge side with a screwdriver and remove from front.
- Lever out cover ② with a screwdriver. Close door.
- Unscrew screw M5 ③.
- Pull hinge component ④ with hinge pin ⑤ out from underneath and remove.
- Open door, lift out at bottom and remove; do not lose the spacer ⑩.
- Transfer all hinge components onto the other side:
- Top: depending on version, proceed as follows:
 - Version 1** (*visible* operating panel): Lever out covers ⑧ with a screwdriver at the front and remove at an angle from below. Remove hinge pin ⑦ and insert on the opposite side. Use the hexagon socket on the open-ended spanner provided (spanner width 5). Fit covers ⑧ again: insert at rear and click into place at front.
 - Version 2** (*concealed* operating panel): Lift up cover ⑧ on handle side, push outwards; lift up cover on hinge side and pull off.
- Unscrew earthing plate ⑪: first earthing screw ⑫, then inner retaining screw ⑬.
- Unscrew hinge ⑨: first undo earthing screw ⑫, then retaining screws ⑬. Fit hinge ⑨ to opposite side: for easy assembly, fit hinge from above and first tighten with the upper retaining screw ⑬ M5, then screw ⑬ and finally earthing screw ⑫ M4.
- Turn earthing plate ⑪ through 180° and screw tight again on the new handle side: first retaining screw ⑬, then earthing screw ⑫.
- Insert hinge pin ⑦ in the other retaining hole. Use the hexagon socket on the open-ended spanner provided (spanner width 5).
- Fit covers ⑧ again: insert hinge-side cover by sliding outwards and click into position; insert handle-side cover by sliding inwards and click into position.

* Depending on model and options

Instructions for installation and modification

- Bottom: Using a screwdriver, remove the spacer (13) and replace on the other side.
 - Re-attach the door:
 - Remove plugs (14) from the door mounting points and replace on the other side.
 - Suspend door with spacer in hinge pin (7), close door.
 - Rotate hinge component (4) by 180°, remove hinge pin (5), turn by 180° and replace. Mount both parts in the hinge (15): slide the pin into the door mounting through the hinge, tilt in the hinge component, slide up and attach with screw (3).
 - Align the door *flush* with the body of the appliance using the slot on the hinge (15), then tighten screw (3).
 - Attach the plinth panel (1) and click into place by pressing.
 - With the door open, insert the cover (2) in the plinth panel at the front and click into place at the back.
 - Transfer* door handle (16) and plugs (18). With the door open, carefully lift out the pressure plates* (17) at the front and slide away; unscrew handle.
- Reassemble in reverse order: replace the pressure plates and click into position.

Insertion into row of kitchen units

Fig. U. 600 mm appliances can be installed in a row of kitchen units. To adapt the height of the appliance to the surrounding furniture a top unit (1) can be added. A gap of at least 50 mm depth must be provided behind and along the entire width of this unit so as to ensure sufficient ventilation. The area of ventilation underneath the ceiling should be at least 300 cm². The greater the area the more economically the appliance will run.

- When installing with standard kitchen units (max. depth 580 mm) and decor panels of max. 2 mm thickness, the appliance can be set up right next to the kitchen unit. The door protrudes 34 mm from the side of the kitchen unit and 51 mm at the front. This enables it to be opened and closed without difficulty.
- When setting up the appliance next to a wall (4), a minimum distance of 36 mm must be provided on the hinge side between the appliance and the wall (for the handle when the door is open).

- | | |
|------------------------|---------------------------|
| ① top unit | ③ kitchen unit side panel |
| ② refrigerator/freezer | ④ wall |

Notes on assembling decor panels

600 mm wide and 1841 mm high appliances can be matched or contrasted with your existing kitchen colour scheme by attaching a decor panel and frames. The panels are available from your kitchen furniture supplier. The frames can be fitted later and are available from your dealer.

If you wish to fit the decor panels yourself, you will need a drill or a rechargeable screwdriver to pre-drill the retaining holes. For further instructions and dimensions see the installation instructions included in the retrofit kit.

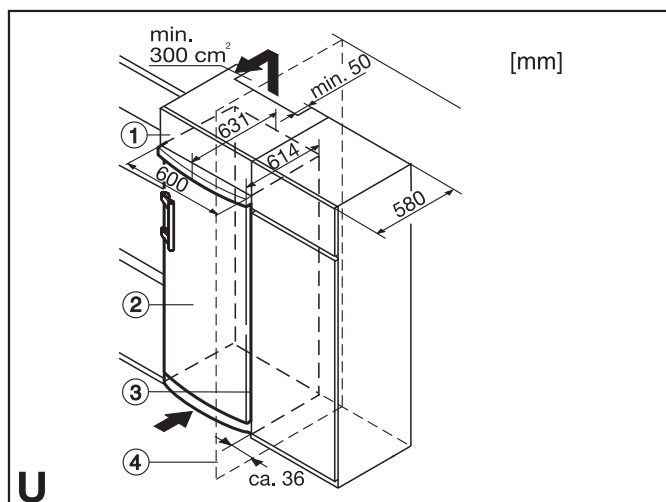
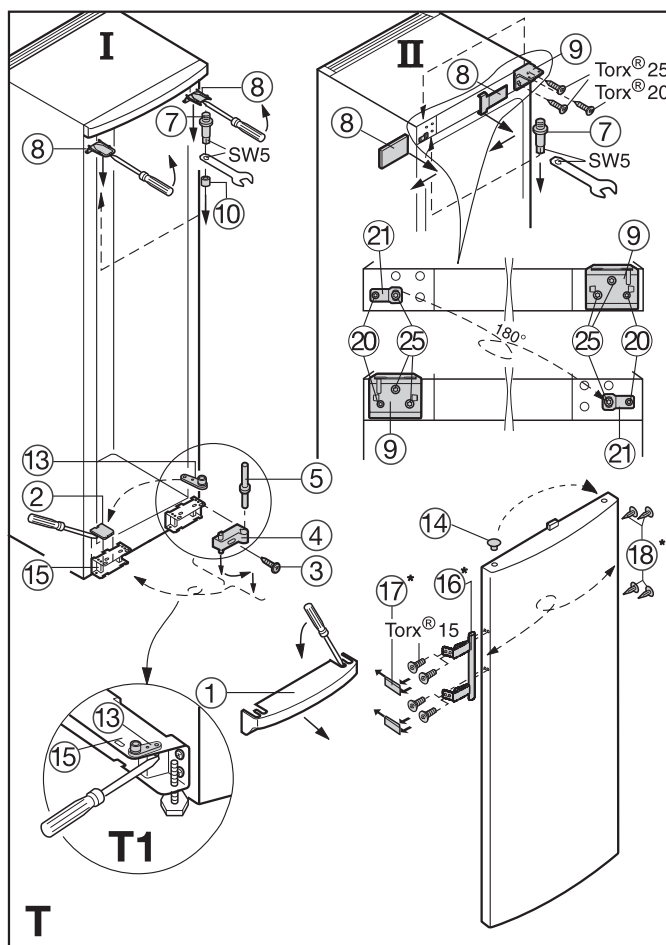
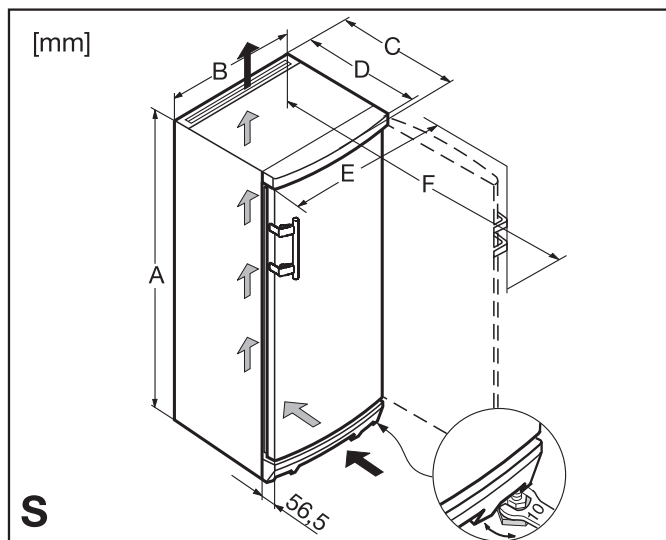

All types and models are subject to continuous improvement and the manufacturer therefore reserves the right to make modifications in the shape, equipment and technology.